

AVERY DENNISON MARKETING SPECIFICATION

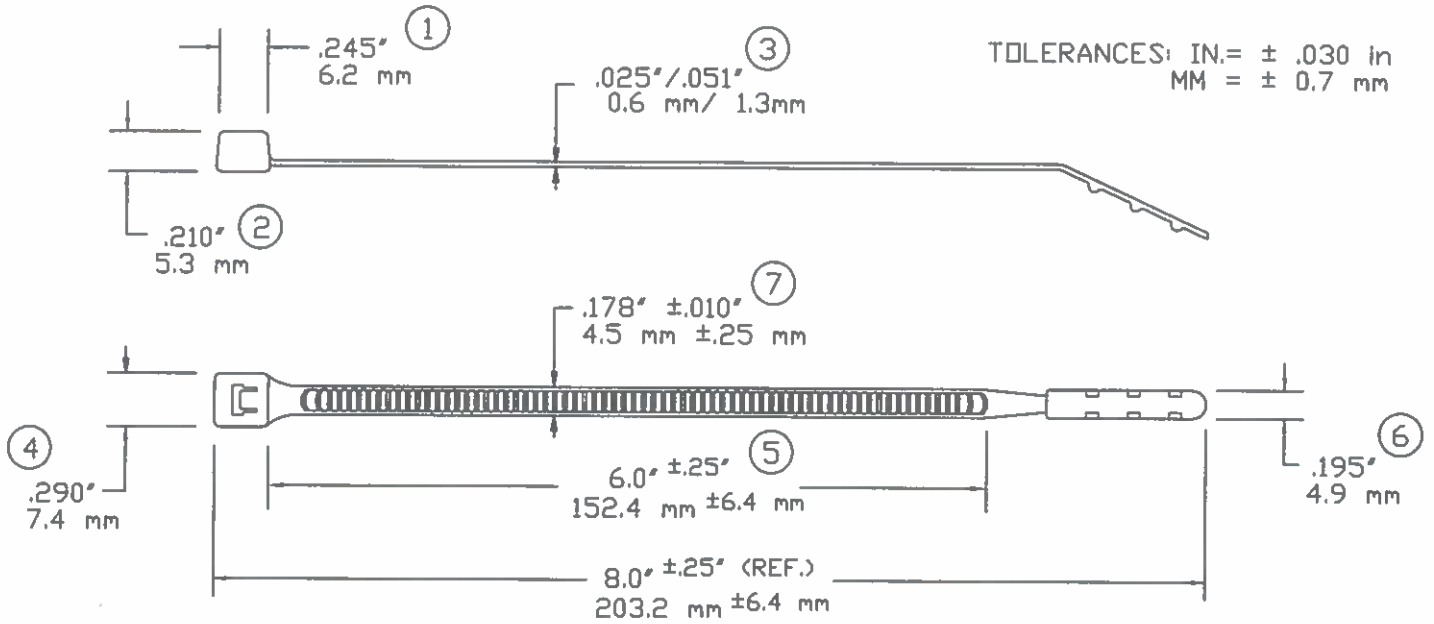

NOT TO SCALE

LOOP TENSILE STRENGTH:	50 Lbf./ 220N MINIMUM
MILITARY STANDARD:	MS3367-1-0
MATERIAL:	NYLON 6/6 - BLACK HEAT STABILIZED
WEIGHT:	.0272 oz. / .80 grams
BUNDLE DIAMETER:	∅0.063"/1.59mm to 1.75"/44.5mm
MIN. INSTALLATION TEMP:	32°F(0°C)
OPERATING TEMPERATURE:	-40°F(-40°C) to 220°F (105°C)
APPLICATION TOOL:	TOOL, HAND ADJUSTABLE, FOR PLASTIC TIE DOWN STRAP. AVERY DENNISON PART NUMBER 12001.
TOOL TENSION SETTING:	6-8
PACKAGED IN:	1000/BAG, 5000/CASE

Plenum rated and has a flammability rating of V-2.

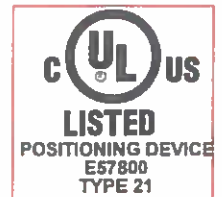

DESCRIPTION:

7.5" SUPER BAR-LOK[®] CABLE TIE
STANDARD

APPROVAL:

L Boyle 4-6-17

STOCK NO.

10003-0

REV
M